



snake 16
on Isuzu M21 - P 2500



ENG



Work area

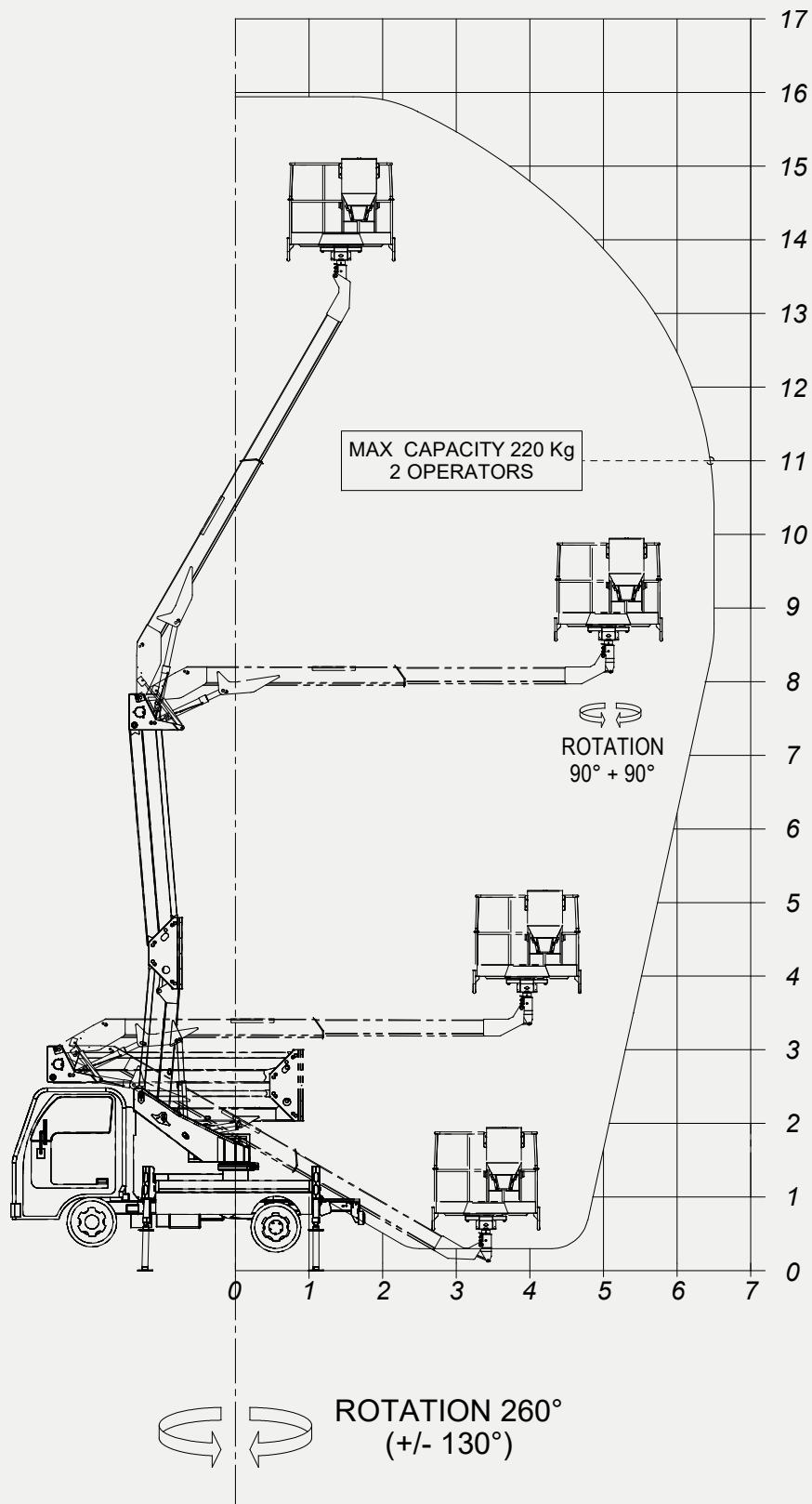

Technical drawings

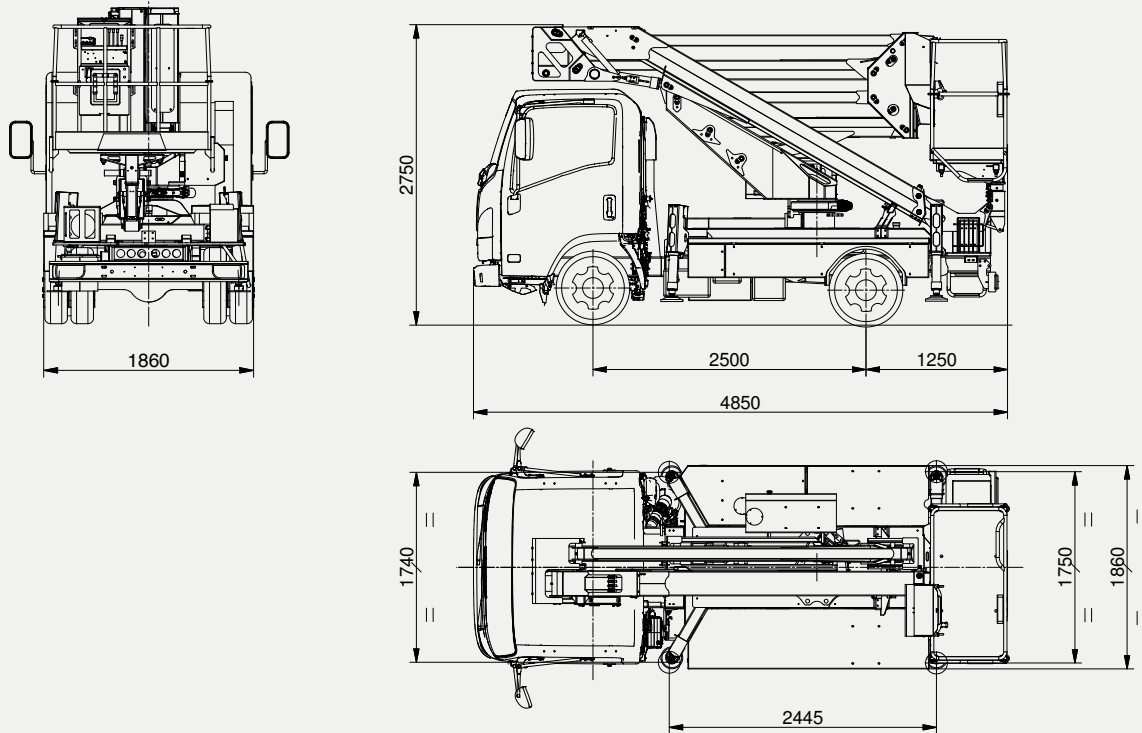

Technical features

Maximum working height	15.9 m
Maximum working outreach	6.5 m
Maximum load capacity	220 kg
Basket	Alu 1.4 x 1.1 x 0.7 m
Controls	Hydraulic
Column rotation	260°
Basket rotation	+/- 90°
Outriggers	H
Machine length	4850 mm
Machine height	2750 mm
Machine width	1860 mm

Optional

Steelwork anti-corrosion treatment

Fibreglass basket 1400 x 700 x 1100 mm (instead of standard version)

Fibreglass basket 1400 x 700 x 1100 mm + 1KV Insulation (instead of standard version)

Extendable structure/cab and chassis anti-collision system

Electronic chassis angle indicator

Multipurpose air-water line to basket

Kit with 4 nylon outrigger support plates

Kit with 2 seat belts with lanyard

Junction debris protection kit (with standard basket rotation)

Junction debris protection kit (with rotating actuator)

12 Vdc electrical socket on basket

12 Vdc electrical socket + 60 W light on basket

12 Vdc electrical socket + LED light on basket

12Vdc - 1.6 Kw electric pump for emergency descent

220 Vac - 2.2 kW single-phase auxiliary electric pump including control panel and battery charger powered from external mains

110 Vac - 2.2 kW single-phase auxiliary electric pump including control panel and battery charger powered from external mains

12 V yellow light magnetised rotating beacon for truck cab

12 V blue light magnetised rotating beacon for truck cab

Triangle for signalling work in progress

Parking chocks

Plastic tool box size 480 x 400 x 400 mm

White - red retroreflective sign

Fixed aluminum side panels 100/150/200 mm height

Drop-down panels on 1 side (right) - 100/150/200 mm height

Drop-down panels on 2 sides - h 100/150/200 mm height

Smaller 40 L diesel tank

Truck cabin painting different from standard

Customer stickers

Remote connectivity kit (+ Industry 4.0 for ITA)

Aerial part painting different from standard

Vehicle air conditioning

ALL SEASON tyres

Car radio with Bluetooth + USB

Steel pads on outriggers

/ Truck standard features

ISUZU M21T Euro 6d D.2500 mm ENGINE 1898 cm³-120 hp (88 kW)

Adjustable steering wheel position (tilt and height)

Electric window lift

Manual headlight height adjustment

Automatic headlight illumination

LED lights

Front and rear fog lights

Central locking with remote control

Sun visor (driver)

Reverse gear warning sound

Seat belt buzzer

Driver's suspension seat

/ Aerial platform standard equipment

Electric PTO with automatic release

Audible PTO engaged device with handbrake released

PTO-connected hour counter on the vehicle dashboard

Warning lights on the hour counter inside the cabin showing pto on and when outriggers are outside the vehicle profile

Switch-on/off of main engine (and any auxiliary engine) from basket and column

Emergency button with engine stop in basket and on column

220 or 110 Vac single-phase electric socket with RCD on basket

Hydraulic aerial controls

Hydraulic outrigger controls

Push-button panel in basket

Torque detection and limitation system

"In shape" stabilization

Hand pump for emergency descent

Piping and cables inside the booms

Two-position aluminium basket 1400 x 700 x h 1100 mm

Hydraulic basket rotation 90° right - 90° left with rotating actuator

Metal covers to protect column and basket controls

Thermal protections on the electrical system

Check valves on all cylinders

Pressure relief valves on the hydraulic circuit

Non-slip aluminium floor

Low Part/Aerial-Part key selector kit

Stainless steel screws

Standard Grey and Blue painting (Grey=Ral 7001 - Blue=Ral 5002)

Plastic pads on outriggers



PM OIL&STEEL SPA
S. Cesario sul Panaro
IT - 41018 - Modena
Via G.Verdi, 22

Tel.: +39 059 936811
Fax: +39 059 936800

info@oilsteel.com
www.oilsteel.com



Oil&Steel is a brand of Manitex International