



scorpion 18
on Iveco P 3750



E N G



Work area

Scorpion 18 on Iveco P 3750 - Front outriggers fully extended

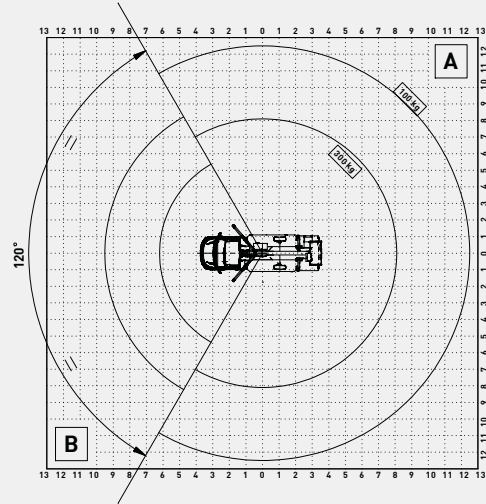
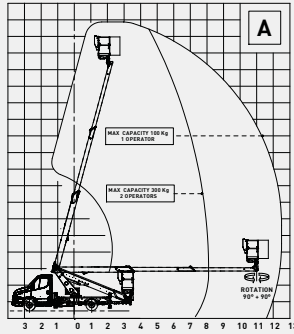
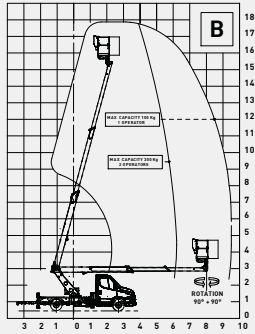

Scorpion 18 on Iveco P 3750 - Front outriggers closed

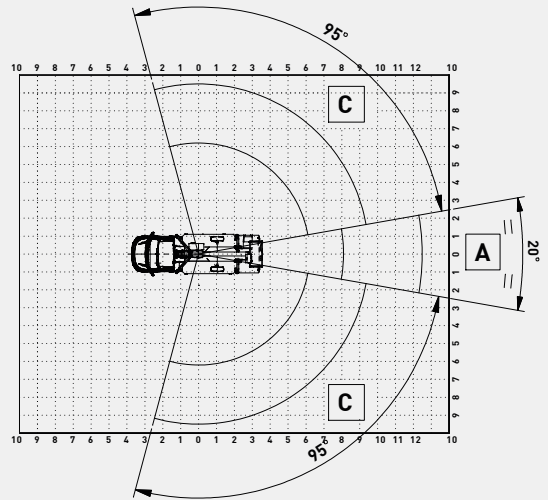
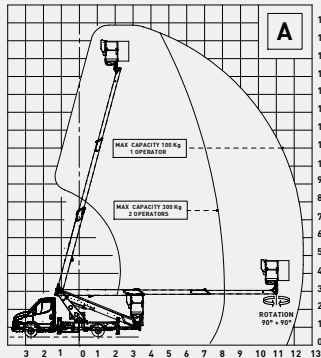
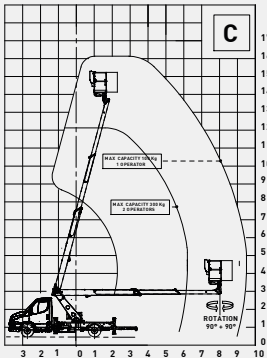

Scorpion 18 on Iveco P 3750 - Front outriggers opened 1 side only

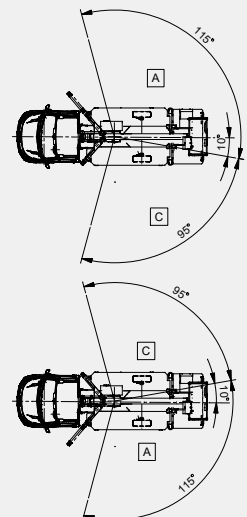
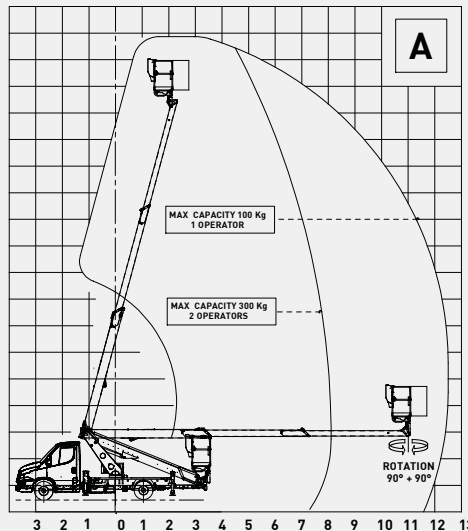
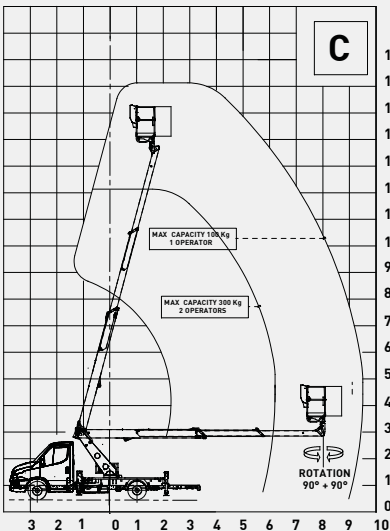

Technical drawings

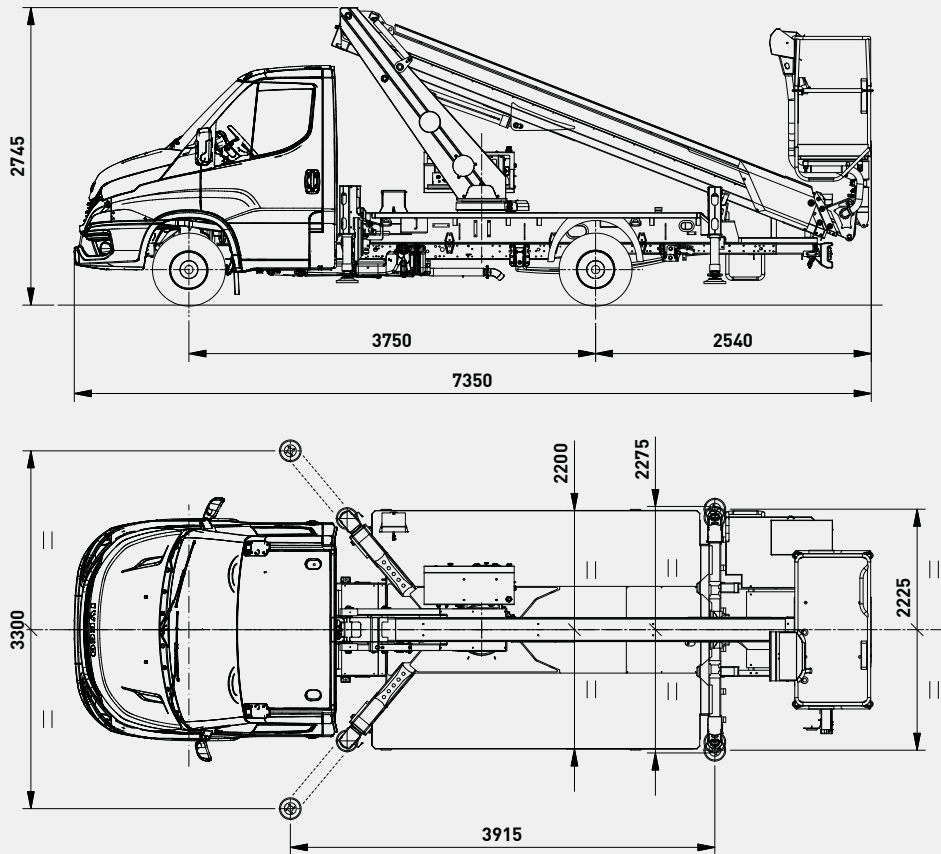

Technical features

Maximum working height	17.8 m
Maximum working outreach	12.5 m
Maximum load capacity	300 kg
Basket	Alu 1.4 x 1.1 x 0.7 m
Controls	Electro-hydraulic aerial part, hydraulic outriggers
Column rotation	+/- 400°
Basket rotation	+/- 90°
Outriggers	HE - H
Machine length	7350 mm
Machine height	2745 mm
Machine width	2275 mm

Optional

Truck cabin painting different from standard

Comfort Pack (Manual air conditioning system, 7" radio with Bluetooth and steering wheel controls, fog lamps, Cruise Control, Seat with lumbar support and armrest)

All season tyres

My Iveco - 7" radio with Bluetooth and steering wheel controls

Fiberglass basket 1400 x 700 x 1100 mm (instead of standard)

Fiberglass basket 1400 x 700 x 1100 mm + insulation 1 KV (instead of standard)

Fiberglass basket with door 1400 x 700 x 1100 mm compliant with STBT200 standard + 1 KV dielectric strength (instead of standard)

Electro-hydraulic outriggers controls - Automatic stabilisation from basket

Automatic stabilisation from ground (only available with electro-hydraulic outriggers controls)

7" touch-screen display on column with protection (only available with electro-hydraulic outriggers controls)

Air-water line supply to the basket

Kit 4 nylon outrigger plates

Kit 2 harnesses

Junction debris protection kit

12V DC socket on the basket

12V DC socket + LED working light on basket

USB plug in the basket (only available with aluminum basket)

Electrical pump 12 V DC 1.6 kW for emergency descent

Auxiliary single-phase 220 V AC - 2.2 kW electrical pump (electrical control panel and battery charger powered by an external source)

Auxiliary single-phase 110 V AC - 2.2 kW electrical pump (electrical control panel and battery charger powered by an external source)

2x Magnetic 12 V revolving orange light for truck cabin

2x Magnetic 12 V revolving blue light for truck cabin

2x 12V amber light rotating beacons for truck cab + bar

2x 12V amber light rotating beacons for truck cab + bar + work in progress warning triangle

Wheel chocks

Plastic toolbox with dimensions 480 x 400 x 400mm placed under the deck

Inox toolbox with dimensions 800 x 350 x 350mm placed over the deck

Underride guards

Red and white reflective decals on truck

Fixed aluminum side panels 150/200 mm height

Drop-down panels on 1 side (right) - 150/200 mm height

Drop-down panels on 2 sides - h 150/200 mm

Aerial part painting different from standard

Customized labels

Remote connectivity kit

Top / bottom key selector

Support kit for outrigger plates, dimensions 300x300x40

Truck standard features

Iveco Daily 35S14H MY24 p.3750mm 136HP (100kW) 2.3L Euro VIe HD - MTT 3,5t	Central Locking with remote control
Mechanical gearbox - 6 gears - 500 Nm	Start & Stop
Single rear wheels	Automatic control of windshield wipers and headlights
Oil tank capacity 40L	Electric parking brake
Intelligent Speed Assistance (ISA)	TFT comfort panel
Driver drowsiness and attention warning (DDAW) system	Rear parking sensors
Tyre pressure monitoring system (TPMS)	Driver and passenger airbag
Proactive Lane Keeping Assist	235/65 R16 eco tyres

Aerial platform standard equipment

Power takeoff with electrical start-up and automatic release	Front outriggers opened 1 side only
Power takeoff on with no handbrake warning siren	Front outriggers fully extended
Power takeoff hour counter fitted on the dashboard of the vehicle	Front outriggers closed
Warning lights on the hour counter inside the cabin showing pto on and when outriggers are outside the vehicle profile	Hand pump for emergency descent
Switch-on/off of main engine (and any auxiliary engine) from basket and column	Emergency stop button bypass
Engine emergency stop button from the basket and from the column	Plastic pads on outriggers \varnothing 200
Single-phase, 220 or 110 v ac power socket and differential overload switch fitted on the basket	Hoses and cables inside the booms
Electro-hydraulic aerial controls	Basket with ladder
Outriggers hydraulic controls	Two-person aluminum basket with dimensions 1400 x 1100 x 700 mm
Hydraulic extension of crossbeams	Hydraulic rotation of the basket 90° right - 90° left with rotating actuator
Crossbeams extension-retraction block when platform is stabilized	Protective casing on the control box on the column and on the basket
Push-button panel in basket with levers	Thermal protection on the electrical system
Chassis control panel for emergency aerial movement control	Lock valves on all cylinders
Moment detection and limiting system	Hydraulic circuit maximum pressure valves
Boom position / extension control system	Anti-slip aluminum decking
Homing Function	Boom and platform treated using corrosion-resistant paint, screws in stainless steel
Extendable structure/cab and chassis anti-collision system	Standard Grey and Blue painting (Grey=Ral 7001 - Blue=Ral 5002)



PM OIL&STEEL SPA
S. Cesario sul Panaro
IT - 41018 - Modena
Via G.Verdi, 22

Tel.: +39 059 936811
Fax: +39 059 936800

info@oilsteel.com
www.oilsteel.com



Oil&Steel is a brand of Manitex International